

Shell Quick Charge Car Charger

Mini 63W 2 Port QC + PD USB Charger Adapter

SCC-63-1C1A

© 2020 Shell Brands International AG. All rights reserved.
Car Charger is part of the Shell Energy range of products.
Shell and the Shell Pecten logo are trade marks of Shell.
Used under license.

IMPORTANT SAFETY INSTRUCTIONS

1. This manual contains important safety and operating instructions.
2. Before using battery charger, read all instructions and cautionary markings on battery charger, battery, and product using battery.
3. **CAUTION** - To reduce risk of injury, charge only rechargeable batteries. Other types of batteries may burst causing injury to persons and damage.
4. Do not expose charger to rain, moisture, or snow.
5. Use of an attachment not recommended or sold by the battery charger manufacturer may result in a risk of fire, electric shock, or injury to persons.
6. Do not operate charger with damaged cigarette lighter connector - replace it immediately.
7. Do not operate charger if it has received a sharp blow, been dropped, or otherwise damaged in any way; take it to a qualified service person.
8. Do not disassemble charger.
9. To reduce risk of electric shock, unplug charger before attempting any maintenance or cleaning.
10. Connect the charger to a 12 V or 24 V electrical system only. Some vehicles operate on 36 V electrical systems. Refer to vehicle operator's manual.
11. Using the charger for extended periods of time can completely discharge your vehicle's battery. Unplug the charger whenever the engine is switched off for extended periods of time. The power does not turn off after switching off the engine in some vehicles. If the charger is left connected, your vehicle's battery may become discharged.

12. When connecting external USB cable(s), route them in a manner that does not interfere with driving.

Customer Service

Please contact customer service for questions, comments, warranty, support or service related to the product at:
Email: support@skyintelligent.com
Website: www.skyintelligent.com/support
Sky Intelligent Investment Limited.
Room 10-12, 6/F, Kwong Sang Hong Centre,
151-153 Hoi Bun Road, Kwun Tong Kowloon,
Hong Kong.

SAVE THESE INSTRUCTIONS

Intended Use

- This charger is intended for charging cell phones, tablets, cameras and similar IT equipment. Do not use it to charge devices with a total power requirement of more than 45W per each charging socket.
- This charger is intended for private use only. It is not intended for commercial use.
- This charger is intended to be used in dry indoor areas only.

PARTS AND FEATURES

Item	Part Name
1	Type-C charging socket
2	USB-A charging socket
3	Power indicator
4	Negative pole shrapnel
5	Cigarette lighter connector
6	Positive pole shrapnel

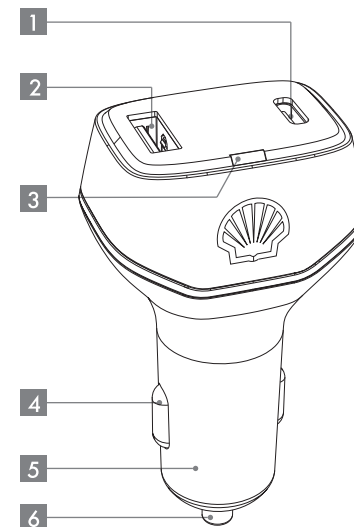

OPERATING INSTRUCTIONS

NOTICE

It is recommended to use the charger only after starting the vehicle's engine to avoid discharging of the vehicle's battery.

- Insert the charger into the cigarette lighter receptacle. The power indicator lights up. **3**

3.0A max. 18W

3.0A max. 45W

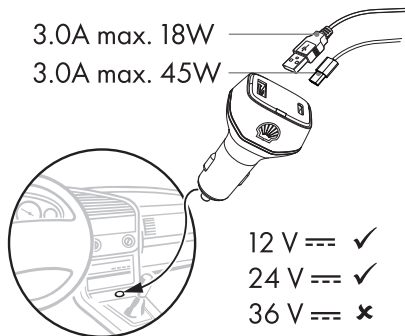

12 V \checkmark

24 V \checkmark

36 V \times

- Connect an external device(s) to the charger using an USB type-A charging cable (not provided).
- After use, disconnect the USB-A cable from the charging socket **1** and unplug the charging from the cigarette lighter receptacle.

TROUBLESHOOTING

Problem Possible Cause

The power indicator does not light up.

The cigarette lighter receptacle is not in the power supply mode. Refer to the operating instructions of your vehicle to enter the power supply mode.

Ensure the charger is connected to the 12 V or 24 V electrical system.

MAINTENANCE INSTRUCTIONS

Cleaning

- Unplug the charger before cleaning.
- During cleaning do not immerse the charger in water or other liquids. Never hold the charger under running water.
- To clean the charger, wipe with a soft, slightly moist cloth.
- Never use corrosive detergents, wire brushes, abrasive scourers, metal or sharp utensils to clean the charger.

Storage

- Store the charger in its original packaging in a dry area. Keep away from children and pets.

SPECIFICATIONS

Model:	SCC-63-1C1A
Power input:	12-24 V \equiv
Power output:	USB : 5V3A/9V2A/12V1.5A Type C: 5V3A/9V3A/12V3A/ 15V3A/20V2.25A
Total output:	63 W

WARRANTY CONDITIONS

- a) We will, at our discretion, repair any product that proves to be defective in material or workmanship during the warranty period of 12 months.
- b) A valid proof of purchase must be presented upon request for warranty service;
- c) The warranty shall not apply if:
 - the product was modified or repaired in any way by persons other than our technicians
 - the product has been damaged through misuse, negligence or inflow of any liquid
 - the product was not used according to user manual
 - losses or damages are caused by force majeure or natural disasters
- d) The warranty terms and conditions are subject to change without prior notice.
- e) Product specifications are subject to change without prior notice.

- f) Visit www.skyintelligent.com/support for support and the latest product information.

FCC COMPLIANCE STATEMENT

1. This device complies with Part 15 of the FCC Rules. Operation is subject to the following two conditions:
(1) this device may not cause harmful interference, and
(2) this device must accept any interference received, including interference that may cause undesired operation.
2. Changes or modifications not expressly approved by the party responsible for compliance could void the user's authority to operate the equipment.

The following importer is the responsible party.
Shell Trading 1000 Main Street, Suite 1700
Houston, TX 77002, USA

FCC INTERFERENCE STATEMENT

This equipment has been tested and found to comply with the limits for a Class B digital device, pursuant to part 15 of the FCC Rules. These limits are designed to provide reasonable protection against harmful interference in a residential installation. This equipment generates, uses and can radiate radio frequency energy and, if not installed and used in accordance with the instructions, may cause harmful

interference to radio communications. However, there is no guarantee that interference will not occur in a particular installation. If this equipment does cause harmful interference to radio or television reception, and on, the user is encouraged to try to correct the interference by one or more of the following measures:

- Reorient or relocate the receiving antenna
- Increase the separation between the equipment and receiver.
- Connect the equipment into an outlet on a circuit different from that to which the receiver is connected.
- Consult the dealer or an experienced radio / TV technician for help.

IC Statement

This device complies with Industry Canada license-ICES-003. Operation is subject to the following two conditions: (1) This device may not cause interference, and (2) This device must accept any interference, including interference that may cause undesired operation of the device.

Le présent appareil est conforme aux CNR d'Industrie Canada applicables aux appareils radio exempts de licence. L'exploitation est autorisée aux deux conditions suivantes : (1) l'appareil ne doit pas produire de brouillage, et (2) l'utilisateur de l'appareil doit accepter tout brouillage radioélectrique subi, même si le brouillage est susceptible d'en compromettre le fonctionnement.